

TRICOM
RESEARCH INC.

**OPERATOR'S MANUAL
TCR-MBA-50 WB
MULTI-BAND RF AMPLIFIER**



DOCUMENT # 90400-01141

Tricom Research, Inc. • <http://www.tricomresearch.com>

17791 Sky Park Circle, Suite J, Irvine, CA 92614

Ph: (949) 250-6024 fax: (949) 250-6023

TCR-MBA-50 WB OPERATOR'S MANUAL

Revision History - Document 90400-01141

Revision	Description	Date
P1	Preliminary Release	23 Feb 2012
P2	Added details of high temperature failsafe operation	28 Feb 2012
P3	Updated current draw specifications, added WB option 11000-00744 information and added Appendix B for Bias Tee installation instructions	25 Apr 2012
A	Official Release	24 Oct 2012
B	Changed Figure 3-7, added auxiliary connector pin 12 description	4 Dec 2012
C	Added TCR-MBA-50 information	15 Mar 2013
D	Changed references to LVL indicator and RF input power	5 Mar 2014
E	Added Figure 3-8 Auxiliary Connector Interface. Updated Table 3-3 Auxiliary Connector Interface pinout	12 Dec 2016
F	Reconcile technical data with data sheet, remove references to TCR-MBA-50	2 April 2018

Note: The latest version of this manual can be downloaded from our website at <http://www.tricomresearch.com/downloads.html>.

TCR-MBA-50 WB OPERATOR'S MANUAL

TABLE OF CONTENTS

1.0	INTRODUCTION	
1.1	General Information.....	1
1.2	Abbreviations and Glossary.....	2
1.3	Equipment Description.....	3-6
1.4	Features.....	7
1.5	TCR-MBA-50 WB System.....	7
1.5.1	Amplifier Components.....	7
1.5.2	Power Cable.....	8
1.6	Specifications.....	8-9
2.0	OPERATION	
2.1	General Information.....	11
2.2	Controls, Indicators, and Connectors.....	11-13
2.3	Operation.....	13
2.3.1	General Information.....	13
2.3.2	Equipment Set-up.....	13
2.3.3	Operating Procedures.....	13
2.3.3.1	Push Button Switch Operation.....	13-15
2.3.3.2	LNA Operation Precautions.....	15
2.3.3.3	Remote Control Operation.....	15
2.3.3.4	Out of Band Operation.....	15
2.3.3.5	Bypass Operation.....	15
2.3.3.6	Troubleshooting.....	15-16
3.0	INSTALLATION	
3.1	General Information.....	17
3.2	Preparation for Use.....	17
3.3	Mounting Provisions.....	17
3.4	DC Input Power.....	20
3.5	RF Interconnections.....	20
3.6	Remote Control Interface.....	22
3.7	Remote Control Command Set.....	25

TCR-MBA-50 WB OPERATOR'S MANUAL

LIST OF TABLES

Table 1-1	Nominal Performance Specifications	8-9
Table 1-2	Interconnect Characteristics.....	10
Table 2-1	Mode Indicators	12
Table 2-2	Power Output Level Indicators	12
Table 2-3	Front Panel Controls	13
Table 2-4	I/O Connectors.....	13
Table 2-5	Troubleshooting Guide	16
Table 3-1	DC Input Power Connector Pinout	20
Table 3-2	DC Input Power Control Pin Functions.....	20
Table 3-3	Auxiliary Connector Interface Pinout.....	23
Table 3-4	Remote Control Command Set.....	25
Table B-1	Bias Tee 3 Troubleshooting Guide	31

LIST OF FIGURES

Figure 1-1	TCR-MBA-50 WB.....	1
Figure 2-1	Amplifier Controls & Indicators.....	11
Figure 2-2	Amplifier Connections.....	11
Figure 3-1	TCR-MBA-50 WB Outline Drawing (1 of 2).....	18
Figure 3-2	TCR-MBA-50 WB Outline Drawing (2 of 2).....	19
Figure 3-3	Amplifier DC Input Connector	20
Figure 3-4	Commercial Vehicle DC Power Cable	21
Figure 3-5	Military Vehicle DC Power Cable.....	21
Figure 3-6	Military Battery DC Power Cable.....	21
Figure 3-7	Auxiliary Connector Pinout	22
Figure 3-8	Auxiliary Connector Interface	23
Figure 3-9	USB Remote Control Cable.....	24
Figure 3-10	RS-232 Remote Control Cable	24
Figure B-1	Military Vehicle DC Power Cable.....	30
Figure B-2	Bias Tee 3 (PA) Installation.....	30
Figure B-3	Bias Tee 3 Interconnect Diagram	32
Appendix A	MS Windows Serial Comm Port Reassignment	26
Appendix B	Bias Tee 3 Installation Instructions.....	29

Note: The information contained herein is for reference only and does not constitute a warranty of performance.

1.0 INTRODUCTION

1.1 GENERAL INFORMATION

This manual provides operating instructions for the TCR-MBA-50 WB Multiband Amplifier shown in Figure 1-1. The TCR-MBA-50 WB amplifier is designed to provide transmit and receive gain for the following modes of operation:

- Multiband line of sight (LOS FM and AM) 30-512 MHz communications
- SINCGARS frequency hopping 30-88 MHz operation
- HAVEQUICK frequency hopping 225-400 MHz
- UHF Tactical SATCOM (242-268 MHz receive and 292-318 MHz transmit) frequencies with Low Noise Amplifier (LNA) and Cosite suppression
- SRW and ANW2 Wideband Networking Waveforms in the 225-450 MHz band

Part number: 11000-00746

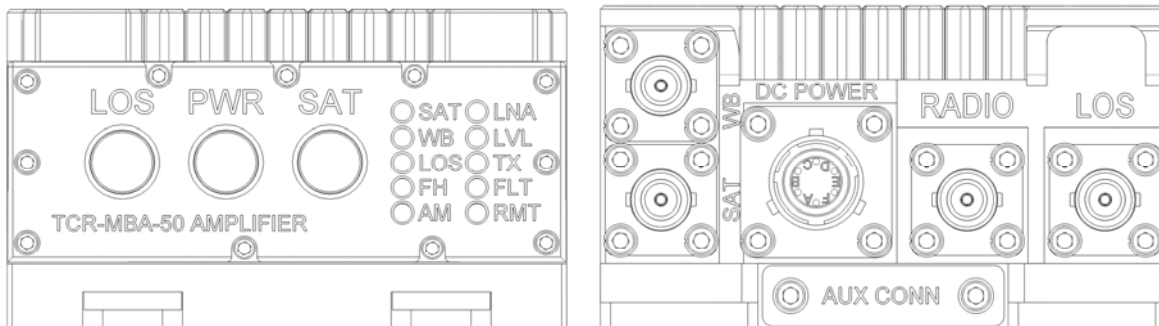

Figure 1-1. TCR-MBA-50 WB

1.2 ABBREVIATIONS AND GLOSSARY

AGC	Automatic gain control
ALC	Automatic level control
AM	Amplitude modulation
ANT	Antenna
ANW2	Advanced Networking Wideband Waveform
BPS	Bits per second
CT	Cipher text
CW	Continuous wave
COMSEC	Communications security
dB	Decibel
dBm	Decibel referenced to 1 milliwatt (0 dBm = 1 mW)
FM	Frequency modulation
Hz	Hertz
IW	Integrated Waveform
JITC	Joint Interoperability Test Center (DISA)
kHz	Kilohertz
LED	Light emitting diode
LNA	Low Noise Amplifier
LOS	Line of sight
MHz	Megahertz
mW	Milliwatt
PT	Plain text
PTT	Push to Talk
RCV	Receive
SATCOM	Satellite Communications
SF	Single Frequency
SRW	Soldier Radio Waveform
UHF	Ultra-high frequency
VDC	Volts, direct current
VSWR	Voltage standing wave ratio
W	Watt
WB	Wideband
XMT	Transmit

1.3 EQUIPMENT DESCRIPTION

The TCR-MBA-50 WB is a bi-directional half duplex RF Power Amplifiers providing transmit amplification for 30-512 MHz FM/AM Line-of Sight (LOS), 30-88 MHz FM SINCGARS Frequency Hopping, 225-400 MHz AM HAVE QUICK Frequency Hopping, 292-318 MHz (transmit band) UHF Tactical SATCOM and 225-450 MHz ANW2 and SRW Wideband Networking bands. A low noise amplifier provides receive gain for the 242-268MHz UHF Tactical SATCOM receive band. It is suitable for vehicular, airborne, man-portable or fixed-station applications and is compatible with most military and commercial radios operating in the 30MHz - 512MHz frequency spectrum. The operation of the amplifier can be controlled locally via front panel switches or from USB and RS-232 interfaces for remote control operation. There is also a Bias Tee 3 available (Tricom Research Part Number 11000-00735) for remote operation of the amplifier. The amplifier has a DC input connection, a radio port and three mode specific antenna ports. The LOS mode port is for AM and FM frequency hopping (non-wideband) and multiband Line of Site operation from 30-512MHz. The SATCOM mode port is band limited to UHF TACSAT Frequencies for 5 and 25 KHz channels, DAMA and IW communications. The WB mode port is used for Wideband Networking and Wideband Frequency Hopping Networking modes.

1.3.1 USER SET MODES.

The following modes are available to the user via the front panel push buttons or with the remote interface:

LOS MODE BUTTON

LOS FM

FREQUENCY HOP FM

LOS AM

FREQUENCY HOP AM

ANW2/SRW WB (Wideband Networking Waveforms)

ANW2//SRW WB HOP (Wideband Networking Waveforms)

SAT MODE BUTTON

SATCOM (LNA ON)

SATCOM (LNA OFF)

The mode button selection determines which output antenna port is active. If the LOS button is pressed while the amplifier is in a SATCOM mode, the amplifier will return to the last used LOS mode. The next LOS button press will sequence to the next available LOS mode. The same is true for the SAT button when pressed while in LOS mode. This way, the user may toggle between set SATCOM and LOS modes by alternately pressing the two mode control buttons, without having to cycle through the entire menu structure. Note that the WB modes are accessed via the LOS mode button.

1.3.2 TRANSMIT POWER LEVELS.

The PA has two available RF output power levels for LOS (25 and 50 W), one RF output power level for ANW2 and SRW WB modes (25 W), and five available RF output power levels for SATCOM (10, 15, 25, 35 and 50 W, in order to comply with MIL-STD-188-181b 2 dB RF output adjustments). These are the maximum available power levels only, as other restrictions, including input voltage, source current limitations, and input power levels may cause the PA to limit output power and also limit the available power level selections. The nominal transmit power level is determined by various factors, the DC input mode (as listed in Table 1-1), the TCR-MBA-50-WB power button on the amplifier front panel, and by the optional remote control interface. The DC power source and source specific DC cable (DC cables are wired differently depending on the end user's DC source), will also determine the maximum allowable current draw, which subsequently determines the maximum allowable output power. The PWR button or the remote interface will then be able to select from the allowable output power levels for each DC cable defined mode:

- **Military Battery Mode (12.5 VDC nominal):**
20 Watts in LOS and WB modes, 10, 15 or 20 Watts in SATCOM and maximum current draw not to exceed 4.75 Amps.

- **Commercial Vehicle Mode (13.8 VDC nominal):**
25 Watts in LOS and WB modes; 10, 15 or 25 Watts in SATCOM and maximum current draw not to exceed 5.5 Amps.

- **Military Vehicle Mode (28 VDC nominal):**
25 or 50 Watts in LOS; 25 Watts in WB and 10, 15, 25, 35 or 50 Watts in SATCOM and maximum current draw not to exceed 6.8 Amps.

1.3.3 POWER ON, INITIALIZATION AND MODE CHANGES.

A single pushbutton switch provides power ON/OFF control, RF output power level control and LED intensity control. Pressing the button momentarily (<2 seconds) will cycle through the different power levels as described in paragraph 1.3.2. Holding the button down longer than 2 seconds will dim the LEDs in 4 steps at 1 second intervals before the PA shuts down; releasing the PWR button before the PA shuts down will set the LED intensity at one of 4 levels (high, medium, medium low, low). The LOS and SATCOM mode buttons will cycle through the operational modes described in Section 1.3.1. Non-volatile memory will remember the last operational state and the PA will return to that state when power is restored.

If PIN E (auto-start) on the DC input power connector is unconnected (open) and the DC supply is disconnected and re-connected the PA will remain in the OFF state until the PWR button is used to turn the PA back on. After turning on, the PA will return to the last operating mode. If

power is shut off using the PWR button and the DC supply is then disconnected and re-connected, the PA will likewise remain in the OFF state.

If PIN E on the DC input power connector is tied to GROUND (auto start configuration) and the DC power is disconnected and re-connected, the amplifier will automatically power ON into the last operational mode. This feature is useful in installations where the front panel is not accessible and DC power is controlled remotely.

1.3.4 MODE OF OPERATION INDICATORS.

There are ten front panel LED's used to indicate the different modes of operation and power amplifier operational status. Table 2-1 describes the LED indicators for the different modes of operation and Table 2-2 describes the different power levels that are available for each mode of operation.

1.3.4.1 SATCOM MODE INDICATOR (SAT).

The SAT LED will illuminate whenever one of two SATCOM modes is selected (SAT LNA ON, SAT LNA OFF).

1.3.4.2 LOW NOISE AMPLIFIER MODE INDICATOR (LNA).

The LNA LED will illuminate whenever the SATCOM/LNA ON mode is selected (SAT LNA ON). When in SAT mode, pressing the SAT button will toggle the LNA on and off.

1.3.4.3 WIDEBAND MODE INDICATOR (WB).

The WB LED will illuminate whenever one of two WB modes is selected (WB Single Frequency and WB Frequency Hopping). Scrolling through the LOS menu (pressing the LOS button) will cycle the user to the WB modes.

1.3.4.4 LINE OF SIGHT MODE INDICATOR (LOS).

The LOS LED will illuminate whenever one of four LOS modes is selected (LOS FM, LOS FM Frequency Hopping, LOS AM, LOS AM Frequency Hopping).

1.3.4.5 FREQUENCY HOPPING MODE INDICATOR (FH).

The FH LED will illuminate whenever one of three frequency hopping modes is selected (LOS FM Frequency Hopping, LOS AM Frequency Hopping and WB Frequency Hopping).

1.3.4.6 AMPLITUDE MODULATION MODE INDICATOR (AM).

The AM LED will illuminate whenever one of two amplitude modulation modes is selected (LOS AM, LOS AM Frequency Hopping).

1.3.4.7 RF INPUT LEVEL UNDER/OVER DRIVE (LVL).

This feature is not currently active but will be implemented in future upgrades.

1.3.4.8 TX STATUS INDICATOR (TX).

The TX LED will illuminate during a good transmit condition. Depending on the duty cycle of some data transmission waveforms such as DAMA, ANW2 and SRW, the TX LED may flicker. This is due to the fast switching time between transmit and receive and DOES NOT indicate a system malfunction.

1.3.4.9 FAULT STATUS INDICATORS (FLT).

The FLT LED will illuminate to indicate a fault condition, such as attempting to transmit at a frequency that is not valid in the selected mode or over temperature conditions.

1.3.4.10 REMOTE OPERATION STATUS INDICATOR (RMT).

The REMOTE LED will illuminate when the PA has received a **REMOTE ON** command from an external terminal and will stay on until the **REMOTE OFF** command has been received. Note that the front panel LOS and SAT buttons are ignored during remote operation.

1.3.5 REMOTE CONTROL INTERFACE.

USB (+5, GND, D+ and D-) and RS-232 interfaces (GND, TXD and RXD only) will provide remote control of the amplifier's modes of operation and power levels. When a terminal has been connected to the remote interface and the proper escape sequence has been sent by the terminal (refer to sections 3.5 and 3.6 for remote control operation) the PA will start communications with the terminal and will illuminate the RMT LED on the front panel. At this point the TCR-MBA-50-WB front panel buttons will become inactive, except to power the amplifier off. The PA will NOT detect the removal of the remote interface connection and will remain in remote mode until the power is cycled OFF, if the remote control cable is unexpectedly removed.

1.4 FEATURES

The TCR-MBA-50-WB has the following features:

- DAMA, DAMA IW and Special Communications modes of operation compatible
- ANW2 and SRW Wideband Networking Waveforms compatible in the 225-450 MHz band
- Coverage from 30 to 512 MHz, including SINCGARS FM and HAVEQUICK AM Frequency Hopping compatibility
- Connections for SATCOM, LOS and WB antennas
- Pre-amplification of received RF signals from antennas connected to the SATCOM port
- Power amplification of transmit signals to 25 or 50 Watts in LOS; 10, 15, 25, 35 and 50 Watts in SATCOM, and 25 Watts in the WB modes
- Transmit and receive band filtering to suppress interference from co-located radios and amplifiers in SATCOM and WB modes
- Amplifier front panel indication of system status

1.5 TCR-MBA-50-WB SYSTEM

The TCR-MBA-50 WB is pictured in Figure 1-1.

1.5.1 Amplifier Components

The Amplifier consists of several printed circuit board assemblies, a filtering and switching network, and RF connectors housed in a water resistant aluminum housing. With normal care and maintenance, the assembly is highly resistant to corrosion from the elements. The RF connections to the RF radio input, SATCOM antenna, LOS antenna, and WB antenna are BNC female (WB antenna BNC connector is not installed on TCR-MBA-50). Power to the amplifier is applied via a cable connected to a six pin circular DC input connector.

1.5.2 Power Cable

A multi-conductor cable connects the amplifier with an external DC power source. A wiring diagram for the cable is shown in Section 3 of this manual. The DC power cable used with the legacy TCR-MBA-25 power amplifier may be used to power the TCR-MBA-50-WB; however, the connection for the Auto Power ON (pin E grounded on the power cable) may have to be added (refer to paragraph 2.3.3.1).

1.6 Specifications

The operating parameters, physical characteristics, and environmental specifications are shown in the following tables.

Table 1-1. Nominal Performance Specifications

TRANSMIT SECTION

SATCOM OPERATION

Frequency Range	292-318 MHz
Switching Speed	JITC DAMA and IW compatible
Modulation	FM or Phase modulation
RF Power Input	2-10 Watts (20W without damage)
RF Power Output	BA-5590 (12.7 VDC 4.75 A max): 10, 15, 20 Watts BB-2590 (15 VDC 4.75 A max): 10, 15, 20 Watts Commercial Vehicle (13.5 VDC 5.5 A max): 10, 15, 25 Watts Military Vehicle (28 VDC 6.8 A max): 10, 15, 25, 35, 50 Watts
Filtering	Cosite suppression

LOS OPERATION

Frequency Range	30-512 MHz with Automatic Frequency Detection
Modulation	AM, FM, AM/FM Frequency Hopping
Band Selection	Fully automatic
RF Power Input	2-10 Watts (20W without damage)
RF Power Output	BA-5590 (12.7 VDC 4.75 A max): 20 Watts Avg/Peak BB-2590 (15 VDC 4.75 A max): 20 Watts Avg/Peak Commercial Vehicle (13.5 VDC 5.5 A max): 25 W Avg/Peak Military Vehicle (28 VDC 6.8 A max): 25, 50 W Avg/Peak

WB OPERATION

Frequency Range	225-450 MHz with Automatic Frequency Detection
Band Selection	Fully automatic
RF Power Input	2-10 Watts (20W without damage)
RF Power Output	BA-5590 (12.7 VDC 4.5 A max): 20 Watts Peak BB-2590 (15 VDC 4.5 A max): 20 Watts Peak Commercial Vehicle (13.5 VDC 5.5 A max): 25 W Peak Military Vehicle (28 VDC 6.0 A max): 25 W Avg

RECEIVE SECTION

SATCOM OPERATION

Frequency Range	242-268 MHz
Noise Figure	3.75 dB typical
Receive Gain	10 dB typical or LNA Bypass

LOS OPERATION

Frequency Range	30-512 MHz
Insertion Loss	<1 dB

WB OPERATION (TCR-MBA-50 WB only)

Frequency Range	225-450 MHz
Insertion Loss	<2.5 dB

ADDITIONAL SPECIFICATIONS

Radio Connector	BNC female
LOS Antenna Connector	BNC female
SAT Antenna Connector	BNC female
WB Antenna Connector	BNC female
DC Connector	MS3112E10-6P
Auxiliary Connector	Optional RS-232 Cable (PN 77500-00390), Optional USB Cable (PN 77500-00391)
High Temperature	High Temperature Indication/Fold back
DC Off	Routes Radio signal to LOS port
Operating Temperature	-30 to +60 C
Cooling	Natural Convection
Dimensions	2" H x 3.5" W x 8.15" D
Weight	3.4 lbs.

The information in section 1.6 is included for reference only and does not constitute a warranty of performance.

Table 1-2. Interconnect Characteristics

Connection	Signal/Pin	Connector Function
DC IN	DC power input	MS3112E10-6P (mating connector for cable use is MS3116F10-6S)
	PIN A	12-32 VDC Input
	PIN B	Electrical GND
	PIN C	Commercial Vehicle Select (12 V)
	PIN D	Military Vehicle Select (28 V)
	PIN E	Auto Power On Select
	PIN F	Reserved
RADIO	RF from radio	Type BNC female
LOS	To LOS Antenna	Type BNC female
SAT	To SATCOM Antenna	Type BNC female
WB	To WB Antenna	Type BNC female

2.0 OPERATION

2.1 General Information

This section provides information for operating the TCR-MBA-50-WB

WARNING

Electromagnetic radiation from the antenna can damage eyes and other body tissue when the system is transmitting. DO NOT stand directly in front of the antenna or in close proximity to the sides or back of the antenna when transmitting.

2.2 Controls, Indicators, and Connectors

The TCR-MBA-50-WB has three push button switches to control:

- Power ON/OFF, LED intensity and RF power level selection (PWR button)
- SAT Modes of Operation (SAT button)
- LOS Modes of Operation (LOS button)
- WB Modes of Operation (LOS button)

There are also several status indicators on the amplifier's front panel as shown in Figure 2-1. The functions of these are specified in Tables 2-1, 2-2 and 2-3

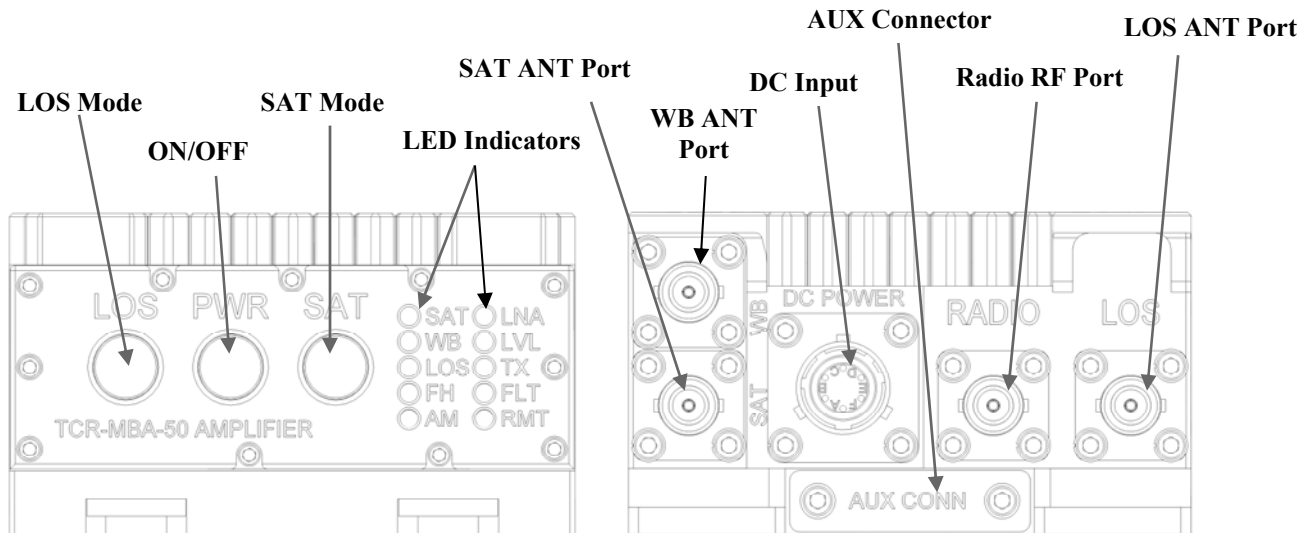

Figure 2-1. Amplifier Controls & Indicators

Figure 2-2. Amplifier Connections

Table 2-1. Mode Indicators

MODE OF OPERATION	LED					
	SAT	LNA	WB	LOS	FH	AM
LOS MODES						
LOS FM				ON		
LOS FREQUENCY HOP FM (SINGARS)				ON	ON	
LOS AM				ON		ON
LOS FREQUENCY HOP AM (HAVE QUICK)				ON	ON	ON
LOS WB ANW2/SRW			ON			
LOS FREQUENCY HOP WB ANW2/SRW			ON		ON	
SATCOM MODES						
SATCOM LNA ON	ON	ON				
SATCOM LNA OFF	ON					

Table 2-2. Power Output Level Indicators

MODE OF OPERATION	LED				
	10 W	15 W	25 W	35W	50W
LOS MODES					
	RMT	FLT	TX	LVL	LNA
LOS FM/AM SF/FREQUENCY HOP 25 Watts	ON	ON	ON		
LOS FM/AM SF/FREQUENCY HOP 50 Watts (Note 1)	ON	ON	ON	ON	ON
WB MODES					
LOS WB SF/FREQUENCY HOP 25 Watts	ON	ON	ON		
SATCOM MODES					
SATCOM LNA ON/OFF 10 Watts	ON				
SATCOM LNA ON/OFF 15 Watts	ON	ON			
SATCOM LNA ON/OFF 25 Watts	ON	ON	ON		
SATCOM LNA ON/OFF 35 Watts (Note 1)	ON	ON	ON	ON	
SATCOM LNA ON/OFF 50 Watts (Note 1)	ON	ON	ON	ON	ON

Note 1: The 35 and 50 Watt power levels are only available in military vehicle mode (pin D grounded on the DC input power connector with a 28 VDC source).

The modes of operation and power levels will cycle in the order indicated in Table 2-1 and Table 2-2 from top to bottom. The settings will cycle through in a loop, to select a different mode or power level, the mode or power switch must be pressed repeatedly until the next desired mode of operation or power level is selected. The power levels are selected by momentarily pressing the PWR button (refer to section 2.3.3). The LEDs for power indication will turn on and remain on as long as the RF output power is being adjusted and will revert back to their normal function 2 seconds after the desired power level is selected. The power level indication will also momentarily illuminate when the modes are changed and at initial turn on of the amplifier.

Table 2-3. Front Panel Controls

CONTROLS	TYPE	FUNCTION
ON/OFF	Push Button Switch	Selects ON or OFF (Bypass) mode of operation, RF output power level (button press <2 seconds), LED intensity (button press >2 seconds but <6 seconds). After 6 seconds the PA shuts down. When in Bypass, the amplifier makes a connection from RADIO input to the LOS connector output.
LOS MODE	Push Button Switch	Selects the LOS and WB modes of operation (refer to Table 2-1)
SAT MODE	Push Button Switch	Selects the SATCOM modes of operation (refer to Table 2-1)

Table 2-4 I/O Connectors

CONNECTIONS	TYPE	FUNCTION
SATCOM Antenna	BNC Type RF connector	Used to attach SATCOM Antenna
RADIO	BNC Type RF Connector	Used to attach to Transceiver
LOS Antenna	BNC Type RF Connector	Used to attach Line of Sight Antenna
WB Antenna	BNC Type RF Connector	Used to attach Wideband Antenna
DC Power input connection	Circular Mil connector	Used to apply DC power input to amplifier
Auxiliary Port	Custom 12 pin flat contact connector	Used for remote control and other special functions

2.3 Operation

2.3.1 General Information

The TCR-MBA-50-WB can be used for operation once it has been installed as described in Section 3.

2.3.2 Equipment Set-up

Refer to Paragraph 2.2 for the locations and functional description of the controls and indicators. Make sure that the TCR-MBA-50-WB has been installed according to the instructions provided in Section 3.

2.3.3 Operating Procedures

2.3.3.1 Push Button Switch Operation

In normal operation, the TCR-MBA-50-WB provides transmit power amplification for radios operating in the 30-512 MHz VHF and UHF bands. The mode switch provides selection for either the SATCOM, LOS or WB modes and the PWR button selects the power levels (Refer to Table 2-1 and Table 2-2). RF output to the SATCOM, LOS or WB antenna ports is automatically selected and determined by the mode selected.

PWR button - ON/OFF- To turn the amplifier ON, press and hold the PWR button for more than 1-2 seconds. The PA will turn ON and display the current power level for approximately 3 seconds. The PWR button cycles the TCR-MBA-50-WB from power ON to power OFF (LOS Bypass mode). To switch the power amplifier back to the Power OFF (Bypass mode) press and hold the PWR button for more than 6 seconds (the LEDs will dim as the PWR button is pressed and held down). When in the Power OFF Bypass mode the RF is automatically routed to the LOS antenna port directly from the transceiver. The Amplifier remembers the last state it was in when powered down.

If the auto power ON mode is selected by grounding pin E on the DC input power connector, the power to the PA can be turned ON or OFF by turning on or off the DC supply. If the auto power ON mode is not enabled, removing the DC power will turn the power amplifier OFF but the PWR button must be used to turn the power amplifier back ON when external DC power is restored.

PWR button – RF Output Power Level Select - To select the desired RF output power level press the PWR button momentarily (< 2 seconds). The power will increase to the next power level from the previously set value on the first button press and will continue to the next allowable level (mode and DC voltage level dependent refer to Table 2-2) for each subsequent PWR button press until the desired level is reached. The LEDs for power level indication will revert back to their normal function approximately 2 seconds after the last button press. Note that in some modes only a single power level is available so the power level display will not change.

PWR button – LED Intensity Level Select- Press and hold the PWR button for more than 2 seconds to select one of four available LED intensity levels (high, medium, medium low, low). As the button is held down for more than 2 seconds, the LED intensity will decrease to the next level; however, if the button is held down for more than 6 seconds the PA will shut down. To select an LED intensity level, simply release the PWR button when the desired brightness is displayed. If the external DC power is interrupted, the LED brightness will default to HIGH when power is restored and the PA is turned back on using the PWR button; however, shutting down and turning the PA back on using the PWR button will remember the last LED intensity level.

LOS Mode- Press the LOS mode button repeatedly to select the desired LOS mode (refer to Table 2-1) or WB mode. When any of the LOS modes are selected, RF is routed to the LOS RF port. Selecting a WB mode routes, the RF to the WB. Frequency hopping can be selected by cycling through the different modes of operation using the LOS mode button as described in Table 2-1.

SATCOM Mode- Press the SAT mode button to select the SATCOM mode (refer to Table 2-1) and to toggle the LNA on and off as described in Table 2-1. The SATCOM mode routes the RF to the SAT port. The LNA provides an average 10 dB receive gain for use in disadvantaged installations where either Omni-directional SATCOM antennas are used or when there are long runs of RF cable loss to overcome.

WB Mode - Press the LOS mode button repeatedly until the WB LED is turned ON (refer to Table 2-1). This indicates that the PA is ready for WB operation and the RF is routed to the WB Antenna port. WB Frequency Hopping is selected when both the WB and FH LEDs are turned on (refer to Table 2-1). This mode is disabled on the TCR-MBA-50.

2.3.3.2 LNA Operation Precautions

There may be an interoperability issue when operating certain radios with amplifiers that have a receive Low Noise Amplifier (LNA). Using the LNA ON setting with certain radios may cause intermittent squelch break on the radio. To resolve this possible issue, simply turn the LNA operation off via the front panel SAT push button switch by selecting SAT LNA OFF.

2.3.3.3 Remote Control Operation

The TCR-MBA-50-WB can be controlled remotely via a USB or asynchronous RS-232 interface (refer to section 3 for a functional description of these interfaces).

2.3.3.4 Out of band operation

Operating outside the frequency band for the selected mode of operation (30-88 MHz FM SINGARS Frequency Hopping, 225MHz - 400MHz AM HAVEQUICK Frequency Hopping, 225MHz - 450MHz WB and 292MHz - 318 MHz UHF SATCOM) will cause the FLT light to flash. The amplifier will go into a “failsafe” LOS bypass mode. The fault will be cleared when the transmit signal is removed. The amplifier will then return to its previous operating mode. Operating on SATCOM frequencies while in the LOS mode with an antenna connected to the LOS port will not cause an alarm and it will operate properly, however, the amplifier will not comply with the timing requirements for DAMA/IW operation. Also note that the PA cannot be “swept” across the 30-512 LOS or 225-450 WB frequency bands as this will cause a frequency fault.

2.3.3.5 Bypass Operation

When DC power is removed or when the AMP Bypass mode is selected (pressing the PWR button for more than 6 seconds) the radio port is directly connected to the LOS antenna port.

2.3.3.6 Troubleshooting

If the communications system seems to be operating improperly, check to make sure that the equipment is configured in accordance with Section 3. If the problem persists follow the instructions below.

Table 2-5. Troubleshooting Guide

SYMPTOM	PROBABLE CAUSE	SUGGESTED FIX
XMT light ON in conjunction with FLT light flashing when transmitting	Incorrect operating frequency for selected mode. Or RF source is sweeping (not fixed frequency)	Change mode or frequency for proper operation. Do not use a swept source
LVL light flashes slow (2 Hz)	Input RF is too low. Or DC input voltage is too low for normal operation (typically 13.5 VDC for commercial vehicle operation and 22-28 VDC for military vehicle operation).	Increase input RF power until LVL LED is off. Increase DC input voltage to the proper level corresponding to the DC input power selected on the power connector. Verify that the proper DC power cable is being used.
LVL light flashes fast (5 Hz)	Input RF is too high.	Decrease input RF power to less than 10 Watts.
Low output power	Low input voltage or low RF drive level. Low battery voltage.	Check DC voltage while transmitting and radio output power setting. Note: The LVL LED will not flash to indicate a low drive condition when operating from a battery (low battery voltage) even though the output power may be low.
FLT light flashes Constantly, output power is reduced.	PA has exceeded its normal operating temperature limit.	Provide additional airflow or reduce transmission time. The PA automatically reduces output power under high temperature conditions.
FLT light ON, Radio connected to LOS port.	PA has exceeded its high temperature limit and is in “failsafe” mode – the equivalent of LOS Bypass.	Operation will return to normal and the FLT light will extinguish once the PA reaches normal operating temperature.
WB light does not illuminate.	Option 11000-00744 not installed.	Verify that option 11000-00744 has been purchased and/or the upgrade has been performed.

3.0 INSTALLATION

3.1 General Information

This section contains information necessary for preparing the TCR-MBA-50-WB for use.

3.2 Preparation for Use

After unpacking the system and inspecting for physical damage, select an appropriate location for the Amplifier. Although the Amplifier is weather-resistant, placing it in a location where it is protected from direct salt spray, rain, and sunlight will increase its service life. Make sure that adequate air flow is available to allow proper convection cooling.

3.3 Mounting Provisions.

The TCR-MBA-50-WB can be mounted using existing mounting holes for the TCR-MBA-25 power amplifier (refer to Figure 3-1). These holes accommodate #10-32 screws, which screw into tapped 10-32 X 0.220 deep holes on the amplifier. Ensure the proper length screw is used to prevent damage to the threaded holes on the amplifier.

The power amplifier can also be mounted by using two mounting tabs in the front and two mounting holes on flanges in the rear. The tabs must be mounted first using 100° #8 flat head screws. To mount the power amplifier, simply slide the two front slots on the front of the power amplifier onto the two tabs and secure the rear flanges with two #4 pan head screws. Other mounting points are included on the sides of the amplifier to accommodate a variety of mounting options.

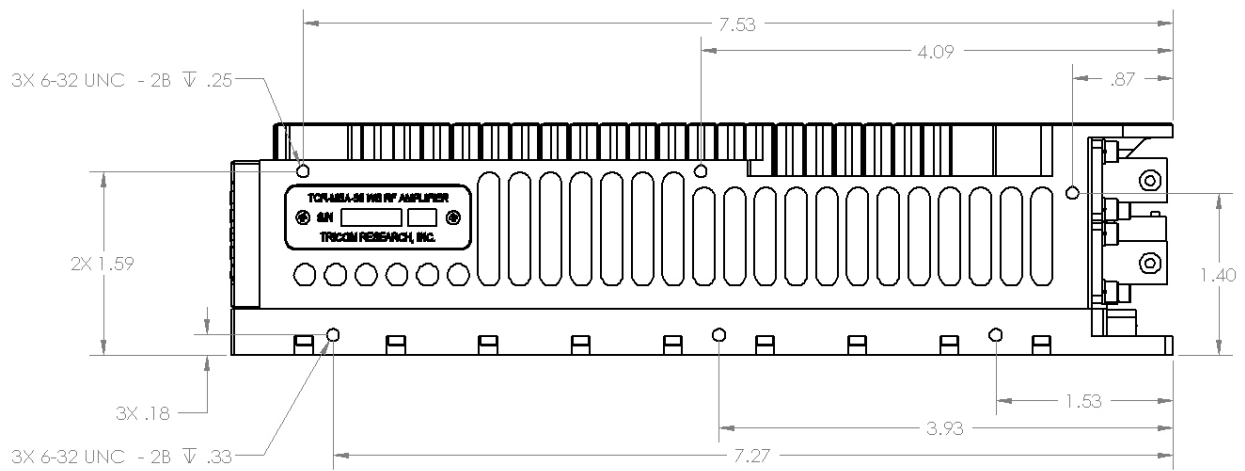
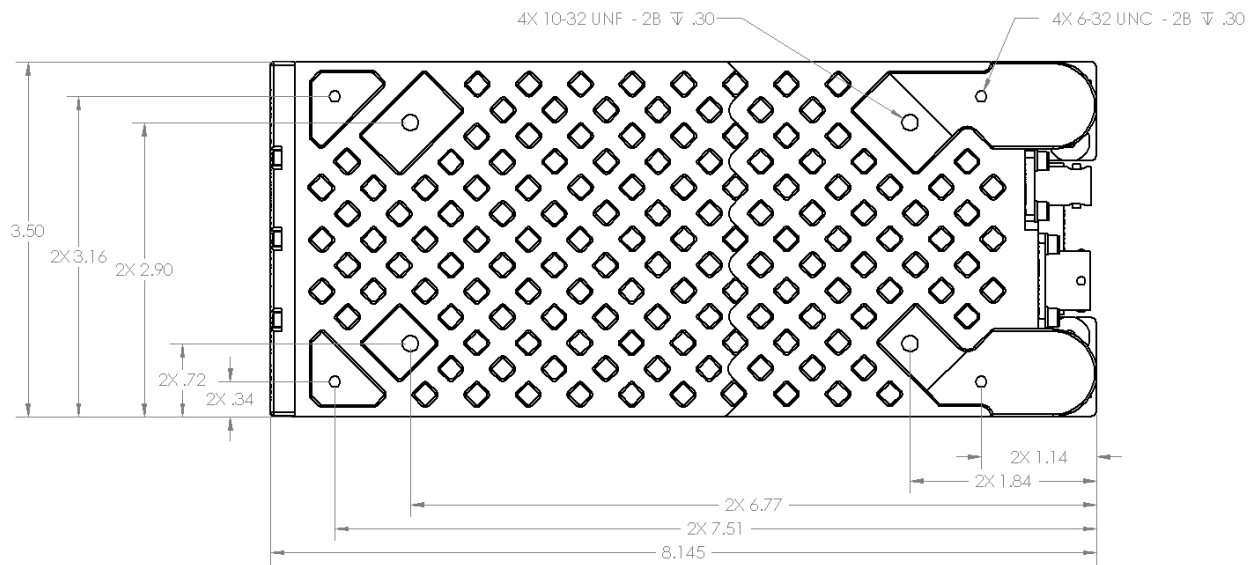

Figure 3-2 TCR-MBA-50-WB Outline Drawing (2 of 2)

3.4 DC Input Power.

The DC input power connector is compatible with the TCR-MBA-25 power cables. Attach the DC power source to the DC IN connector located on the rear of the amplifier (See Fig 3-1 and Table 3-1 for connector pinout and location).

3.5 RF Interconnections.

Attach an RF cable from the transceiver to the Radio Input Connector. Attach RF cables/antennas to the antenna connections located on the rear of the amplifier.

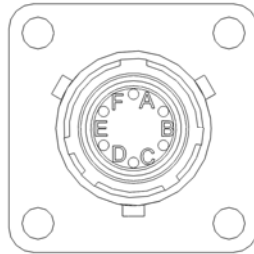

Figure 3-3 Amplifier DC input connector (MS3112E10-6P)

Table 3-1. DC Input Power Connector Pinout

Pin #	I/O	Connection
Pin A	I	12-32 VDC
Pin B	I	GND
Pin C	I	Commercial Vehicle Select
Pin D	I	Military Vehicle Select
Pin E	I	Auto Power ON Select
Pin F	I/O	Reserved

Table 3-2. DC Input Power Control Pin Functions

Pin C	Pin D	Description
OC	OC	Military Battery Mode (12 V nominal)
GND	OC	Commercial Vehicle Mode (13.8 V nominal)
OC	GND	Military Vehicle Mode (28 V nominal)
GND	GND	Reserved

OC = Open Circuit
GND = Ground

Remove cap to replace fuse
 Replace with 3AG 10A 250 VAC
 fast blow fuse

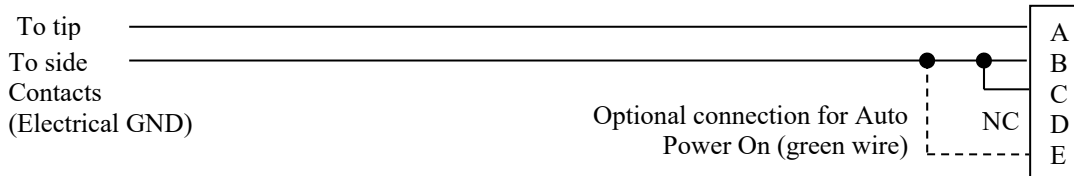
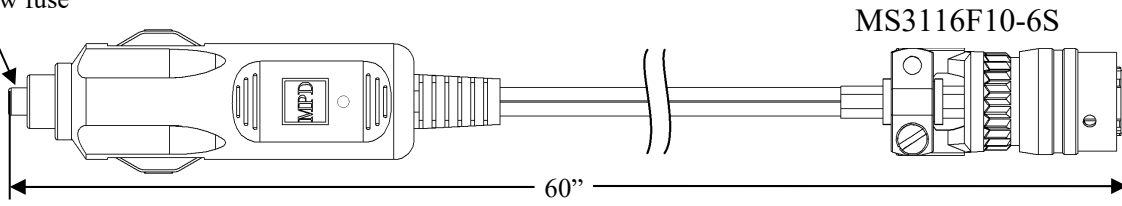

Figure 3-4 Commercial Vehicle DC Power Cable (part number 77500-00411 optional)

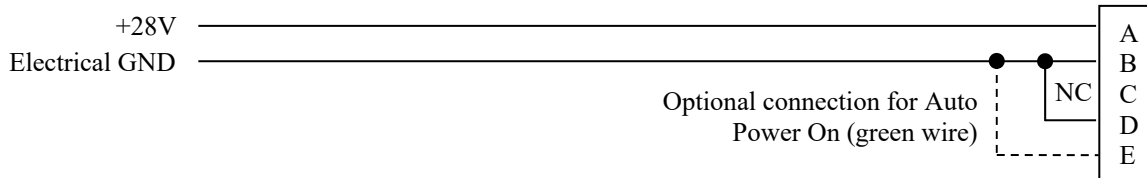
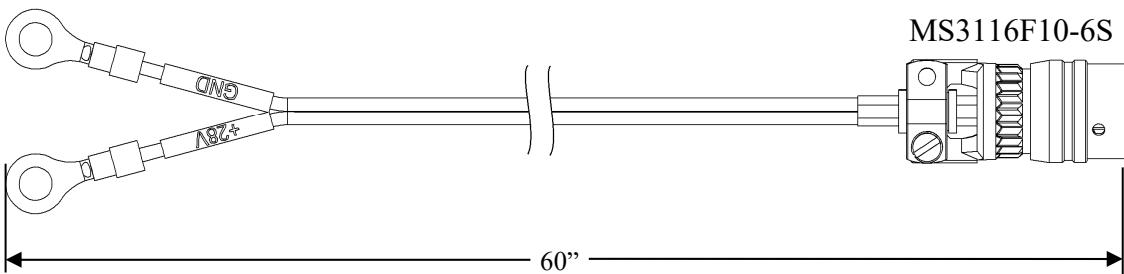

Figure 3-5 Military Vehicle DC Power Cable (part number 77500-00412 included)

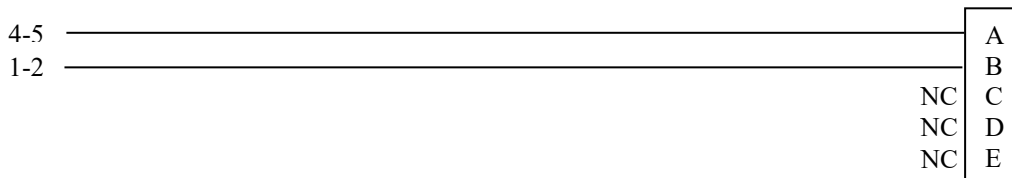
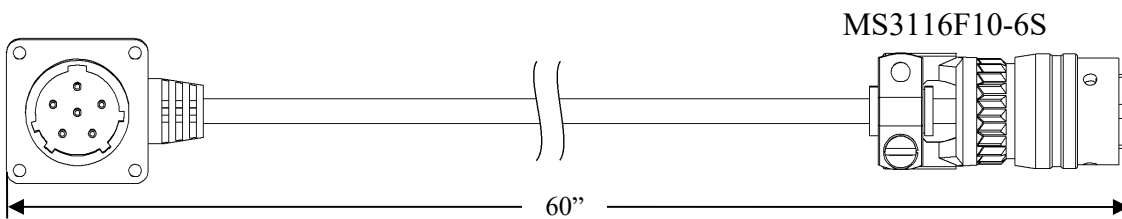

Figure 3-6 Military Battery DC Power Cable (part number 77500-00413 optional)

3.6 Remote Control Interface.

The power amplifier can be controlled via a USB or RS-232 interface using a terminal emulator such as HyperTerminal. To connect the remote control interface cable, remove the dust cover labeled AUX CONN on the connector side of the power amplifier. The operating data parameters for RS-232 are 9600 bps, 8 bits, no parity, and 1 stop bit. To use the USB connection, follow the Windows instructions to install the appropriate USB driver for a virtual serial port. The USB driver can be downloaded from <http://www.ftdichip.com/drivers/D2XX.htm>.

CAUTION

The AUX CONN cover should be installed whenever the auxiliary port is not being used to maintain the environmental integrity of the PA and to prevent damage to the auxiliary connector contacts.

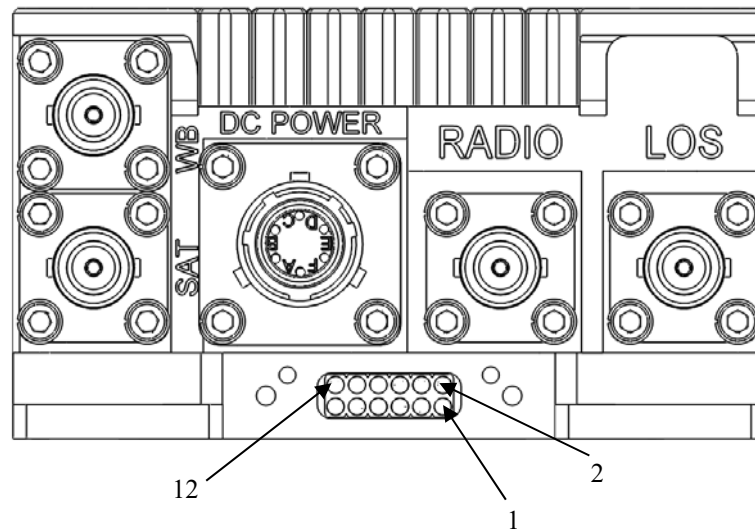

Figure 3-7 Auxiliary connector pinout (mating connector part number 77500-00421)

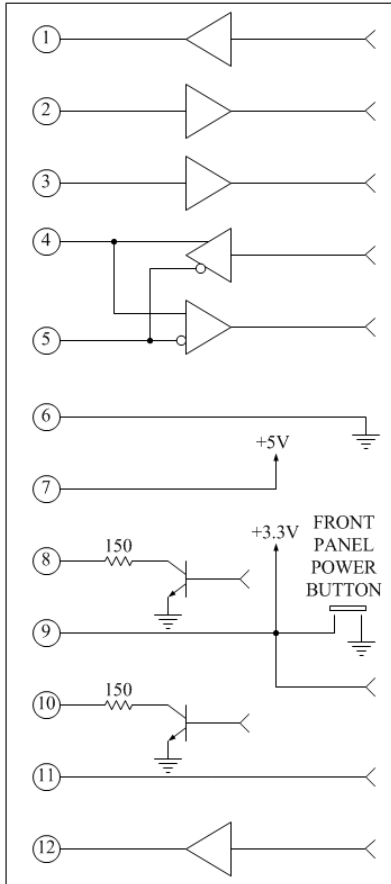

Figure 3-8 Auxiliary Connector Interface

Table 3-3. Auxiliary Connector Interface Pinout

Pin #	Connection
1	RS-232 RXD
2	RS-232 TXD
3	+5 USB
4	USB D+
5	USB D-
6	GND
7	+5 OUT @ 100 mA
8	MODE INDICATION LOW ON LOS OTHERWISE OC
9	REMOTE DC/RF POWER SWITCH - MOM CONTACT TO GND -DEBOUNCE RECOMMENDED
10	TX INDICATION LOW ON RCV OC ON TX
11	RESERVED
12	MODE INDICATION +3.3 LOGIC LEVELS - HIGH IN WB MODES OTHERWISE LOW

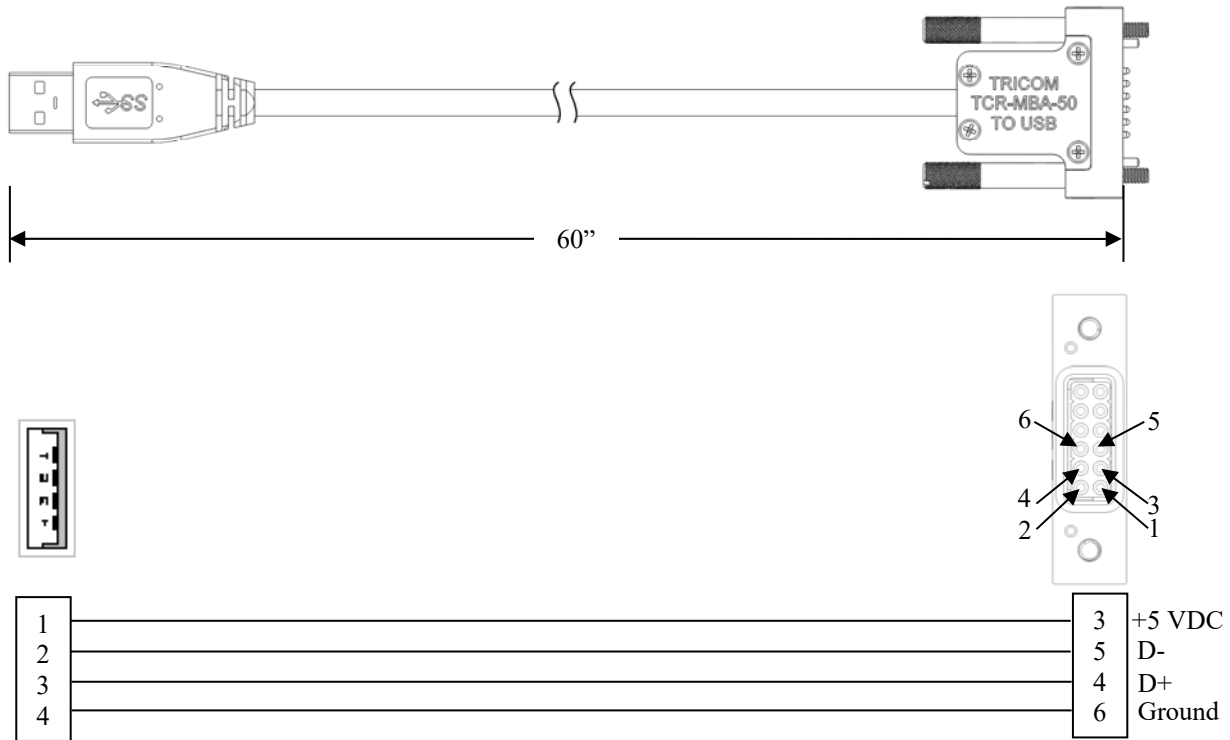

Figure 3-9 USB Remote Control Cable (part number 77500-00391 optional)

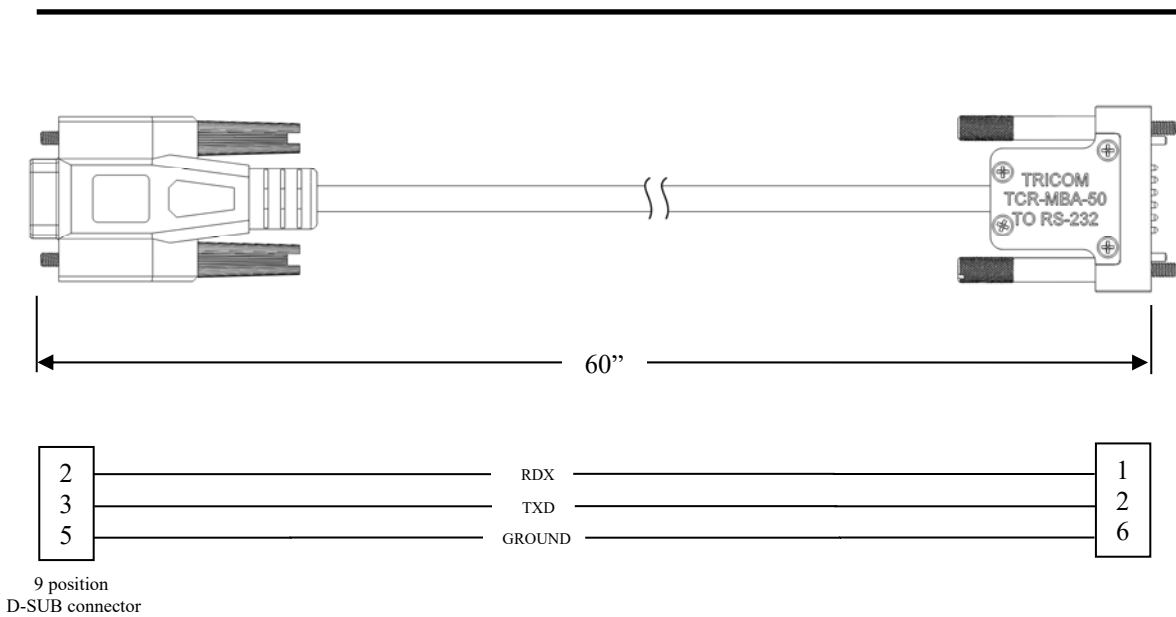

Figure 3-10 RS-232 Remote Control Cable (part number 77500-00390 optional)

3.7 Remote Control Command Set.

Table 3-4 describes the command set for controlling the TCR-MBA-50-WB remotely. Each valid command is responded with an “ack” message; invalid commands due to incompatible operational parameters will be responded with a “nack” message and invalid commands due to syntax errors will be responded with an “unknown command” message.

Table 3-4 Remote Control Command Set

COMMAND	FUNCTION
remote on	Turns on remote control function on the PA (RMT light turns on, mode LOS and SAT mode switches are disabled)
remote off	Turns off remote control mode on the PA (RMT light turns off)
?	Displays command list
status	Displays current status of the PA (firmware versions, mode, power, temperature)
los fm	Selects LOS FM mode
los am	Selects LOS AM mode
los fm hop	Selects LOS SINCGARS mode
los am hop	Selects LOS HAVE QUICK mode
wb	Selects LOS WB single frequency mode (does not apply to TCR-MBA-50)
wb hop	Selects LOS WB frequency hopping mode (does not apply to TCR-MBA-50)
sat lna on	Selects SATCOM mode with LNA turned ON
sat lna off	Selects SATCOM mode with LNA turned OFF
power ##w	Selects the desired power level where ## is any allowable power level (10, 15, 25, 35, 50) for the selected mode of operation. Selecting a power level that is not allowed will return a nack message

APPENDIX A

MS Windows Serial Comm Port Reassignment

Issue: MS Windows automatically assigns comm ports to USB serial communications devices in a sequential order. This may create a problem if a remote control Graphical User Interface (GUI) for the TCR-MBA-50 (both versions) only allows the use of specific comm ports. As an example, if the GUI only allows the use of COM1, COM2 or COM3 to interface to the PA via the USB interface and MS Windows automatically assigns COM12 to the USB serial port adapter embedded in the PA then the PC and the PA will not be able to communicate.

Solution: To resolve this issue, the user may reassign the comm port to the TCR-MBA-50's USB serial adapter port (both versions) by going to the advanced comm port settings in the Device Manager's menu.

Comm port reassignment procedure:

1. Ensure that the USB driver for the USB to serial adapter in the PA is installed on the computer. The driver is loaded on the CD that ships with the PA or it can be downloaded from <http://www.ftdichip.com/drivers/D2XX.htm>.

NOTE: The driver must be installed first before the PA is connected to the PC.

2. Ensure that the PA is turned OFF.
3. Connect the USB interface cable to the AUXILARY port on the PA and to any available USB port on the computer.
4. Turn ON the PA.
5. Open the **Device Manager** on the computer and expand the **Ports (COM & LPT)** list to view all enabled comm ports on the computer

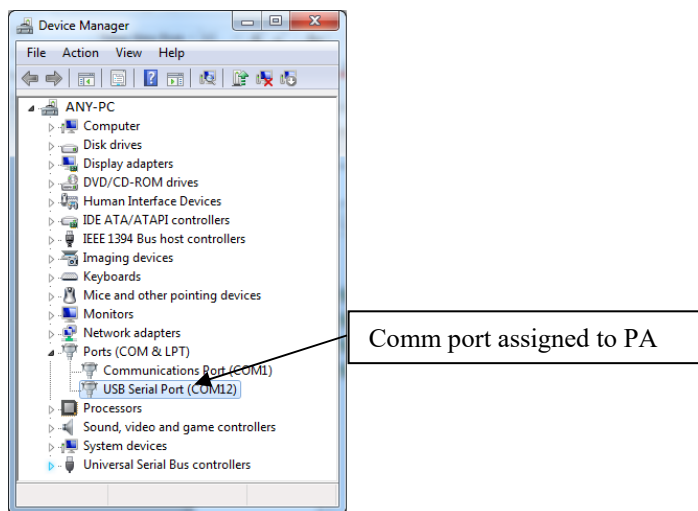

6. Double click on the **USB Serial Port** assigned to the PA (COM12 in this example) to view/change its settings.

7. Click on the **Port Settings** tab and select **Advanced...**
8. Click on the **Comm Port Number:** drop down list and select the desired comm port.

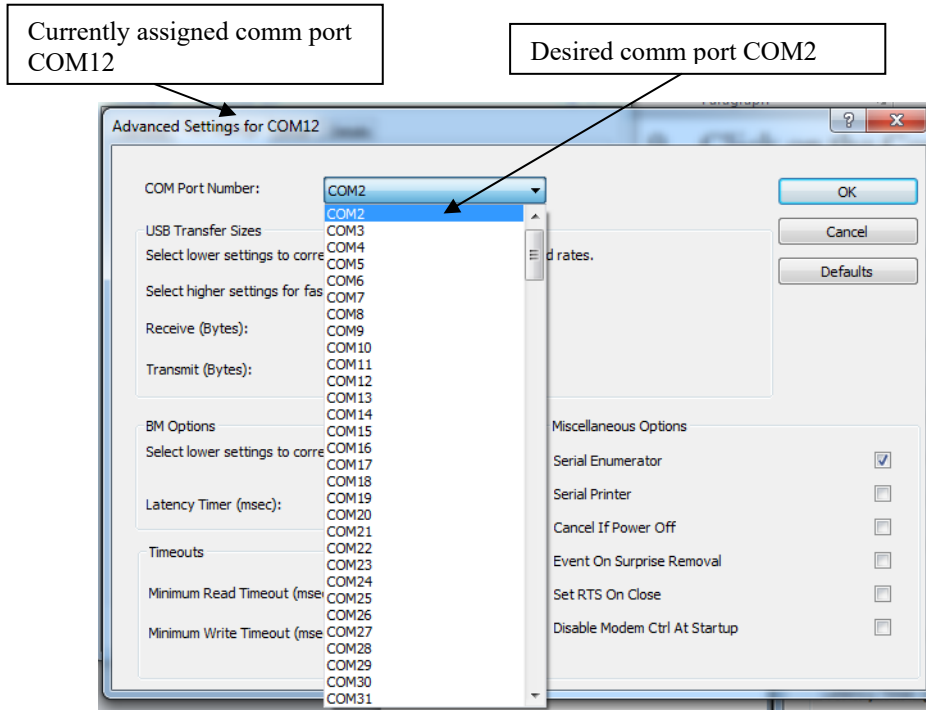

9. Click OK on the advanced settings window and verify that the reassigned comm port settings are 9600 bps, 8 bits, no parity, 1 stop bit and no flow control.

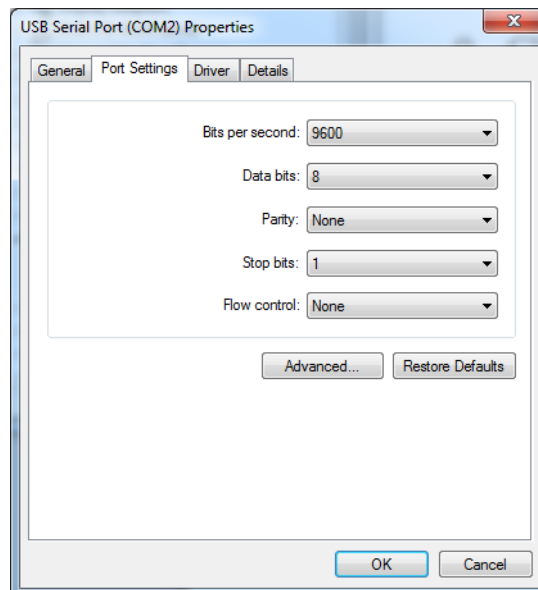

10. Click OK on the **USB Serial Port Properties** (COM2 in this example) window to return to the Device Manager main window.

11. Verify that the desired comm port (COM2 in this example) is enabled.

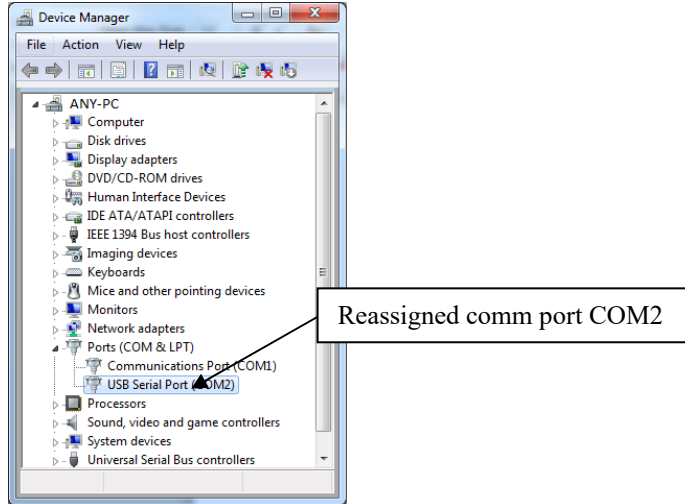

12. Exit Device Manager.

13. Run the remote control utility being used to communicate with the TCR-MBA-50 and verify that the PC is communicating with the PA.

NOTE: Any communications terminal software such as HyperTerminal can be used to communicate with the PA. Windows 7 does not include the popular HyperTerminal software but there are several freeware communications terminal emulation utilities available for download on the internet such as PuTTY, which can be downloaded from <http://www.putty.org/>.

APPENDIX B

Bias Tee Installation Instructions

1. Equipment Preparation.

- a. Mount TCR-BT-01-2 to the power amplifier as depicted in Figure B-2.

Note: The TCR-BT-01-2 Bias Tee is compatible with the TCR-MBA-50 WB.

- b. Connect the antenna to the appropriate port on the PA (SAT, LOS or WB).
- c. Connect RADIO jack on TCR-BT-01-1 to the appropriate radio RF input/output port as depicted in Figure B-2.
- d. Ensure DC power source (28 VDC recommended) is turned off and connect it to the DC INPUT jack on the TCR-BT-01-1 (see Note 1 below for more information regarding DC input). Refer to Figure B-1 for DC Power cable pinout.
- e. Connect the coax cable between the two N connectors on the TCR-BT-01-1 and TCR-BT-01-2.

2. Operation.

- a. Turn on the DC power source and verify that the DC INPUT LED illuminates on TCR-BT-01-1 and that DC ON at both Bias Tee ends is OFF.
- b. Press and hold the power button on TCR-BT-01-1 until DC ON illuminates (2-3 seconds).
- c. Verify that DC ON at TCR-BT-01-2 is also illuminated.
- d. Verify that the power amplifier is ON and select the appropriate mode of operation and power level.
- e. Turn on the radio and select the appropriate channel for operation.
- f. Key the radio and observe that the TX light on the TCR-BT-01-1 and on the power amplifier illuminate.
- g. Refer to Table B-1 for system troubleshooting in the event that any of the steps above fail to provide the normal indication.

NOTE: The TCR-BT-01-2 is wired for auto start and 28 VDC operation for the TCR-MBA-50-WB. The PA will still operate at voltages as low as 12 VDC; however, the current limiting function for battery or commercial vehicle operation will not be enabled and the PA will try to TX at higher power levels, up to 50 watts (mode dependent). This will draw higher than normal current and could potentially trip the overcurrent protection on some batteries, such as the BA-5590.

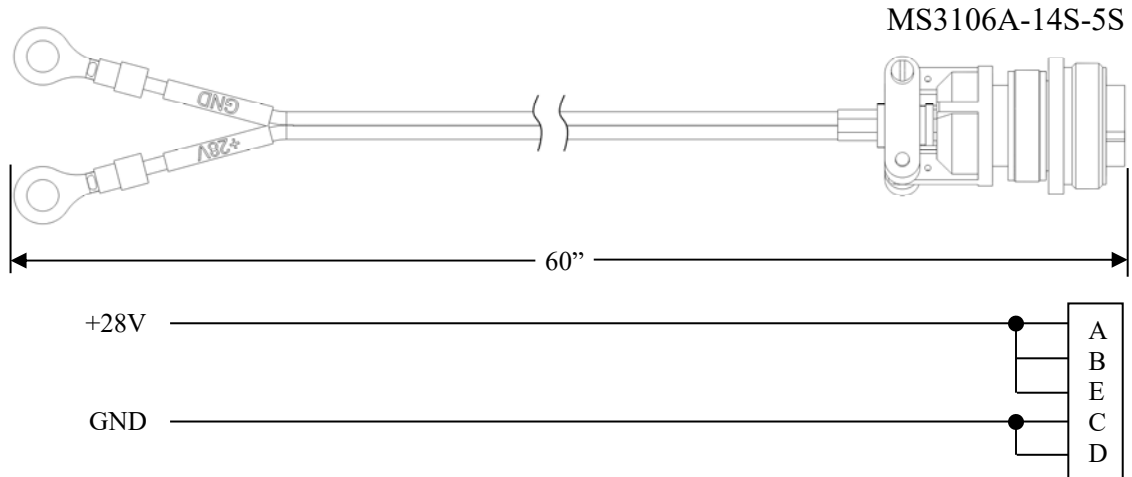

Figure B-1 Military Vehicle DC Power Cable (part number 1035-77200-00006 included)

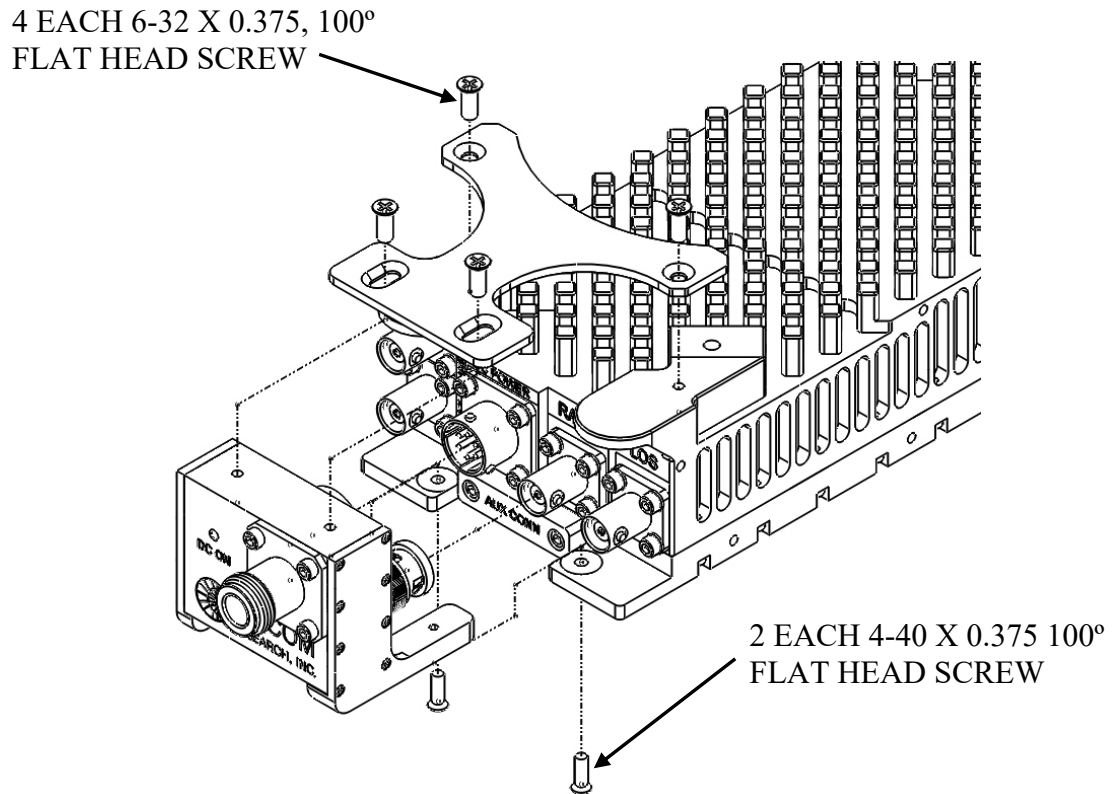

Figure B-2 Bias Tee 3 (PA) Installation

Table B-1. Bias Tee 3 Troubleshooting Guide

SYMPTOM	PROBABLE CAUSE	SUGGESTED FIX
DC INPUT ON but DC ON at TCR-BT-01-1 (radio end) does not illuminate	Possible short on coaxial cable between the two Bias Tees.	Disconnect coaxial cable from TCR-BT-01-01 and verify that DC ON illuminates. Replace coaxial cable if necessary.
DC ON at TCR-BT-01-2 (PA end) does not illuminate	Possible open on coaxial cable between the two Bias Tees.	Verify that the coaxial cable between the two Bias Tees is good and properly connected to the N connectors. Replace coaxial cable if necessary.
TX LED at TCR-BT-01-01 does not illuminate when the radio is keyed	This condition indicates that the power amplifier is NOT drawing any current. PA may be either turned off or in a fault condition i.e. wrong frequency for mode selected on the PA.	Verify that the PA is turned ON and in the proper mode of operation.

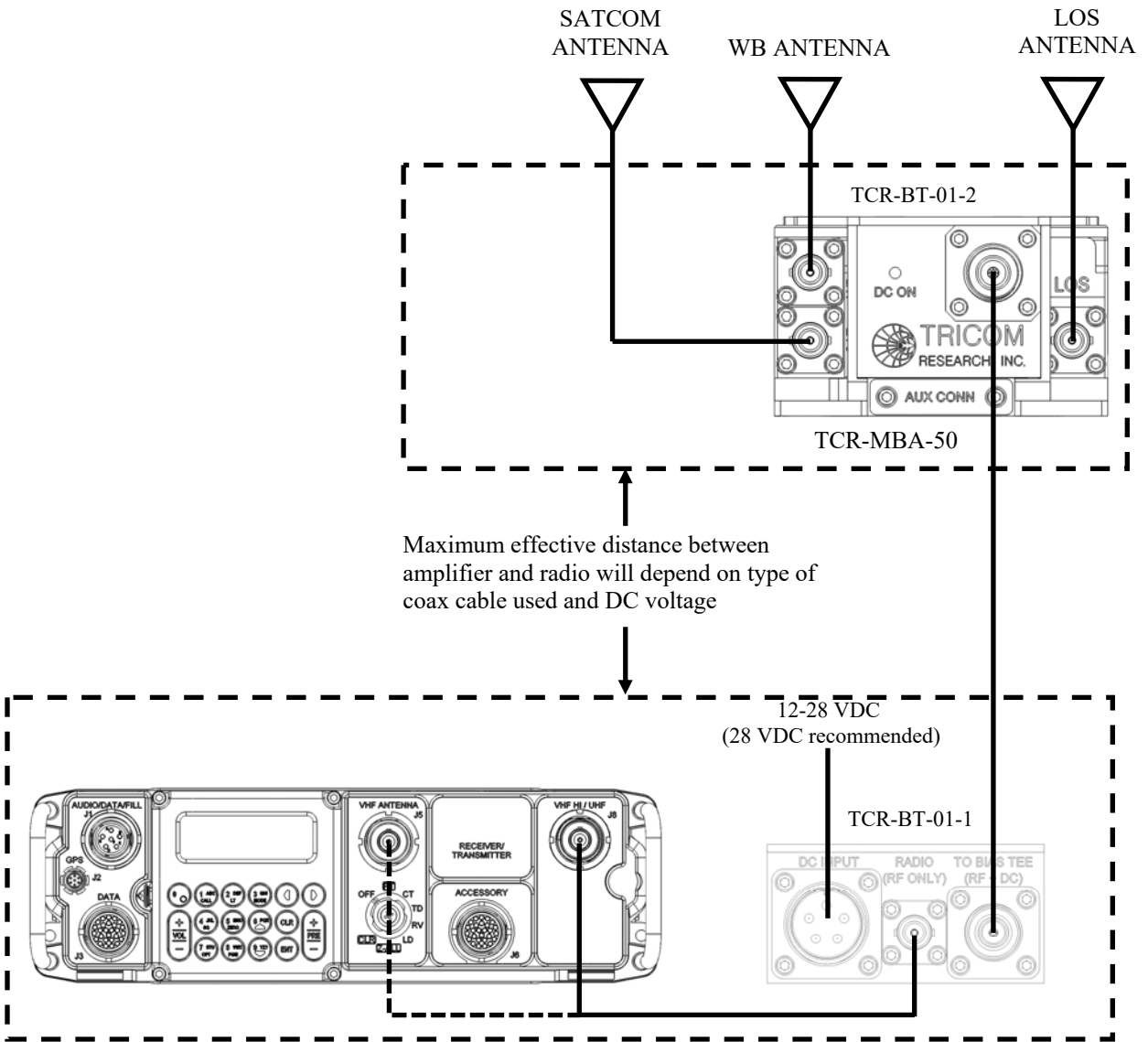

Figure B-3 Bias Tee 3 Interconnect Diagram